

# ES52 Autostart Engine Controller

## For Diesel and Gas Engines

The ES52 is designed to provide autostart control and protection for all types of diesel and gas engine-driven equipment.

The module is epoxy sealed in an ultra-compact package with mounting compatibility to an industry standard footprint.

The module is easily configured using on-board DIP switches and potentiometer adjustments.

- Epoxy sealed for protection against vibration, shock, and moisture.
- Multi-Function Timer Output: Pre-heat, Slow, Airgate, & Choke.
- Warm-up Timer Output.
- Detects lost speed signal.
- Zero speed restart prevents starter pinion wear.
- 5-Year Warranty.

## Simple Installation and Servicing

- Plug-in Terminals with no wire crimping required.
- 20A Removable Relays and a fuse eliminate slave relays and external fusing in most installations (fuel/crank circuits are rated 20A combined)
- Works with Mag Pickup, Alternator or Genset Output (300V max).
- Field Settings with potentiometers and DIP switches.
- Setup mode for quick calibration.

## Ordering Information

**Part No: ES52-0000-12-A-08-LS\***

\*Comes with 12VDC relays installed. Consult factory for part numbers for special order controllers.

Available Accessories:  
RLY0017 - 24V relays



**ES52 showing on-board 20A relays, fuses, and annunciator strip**

## BY SPECIAL ORDER

The ES52 also offers the following features available by special order. Please contact DynaGen for details.

- Preset Calibration with Fixed Settings to prevent tampering
- Under-speed shutdown
- Mid-heat & Post-heat functions (during and after cranking)
- Cool-down timer
- Pull/Hold Coil control for fuel solenoid
- Momentary inputs for multiple start/stop locations
- Inputs for Photocell start/stop control

## Typical Wiring Example

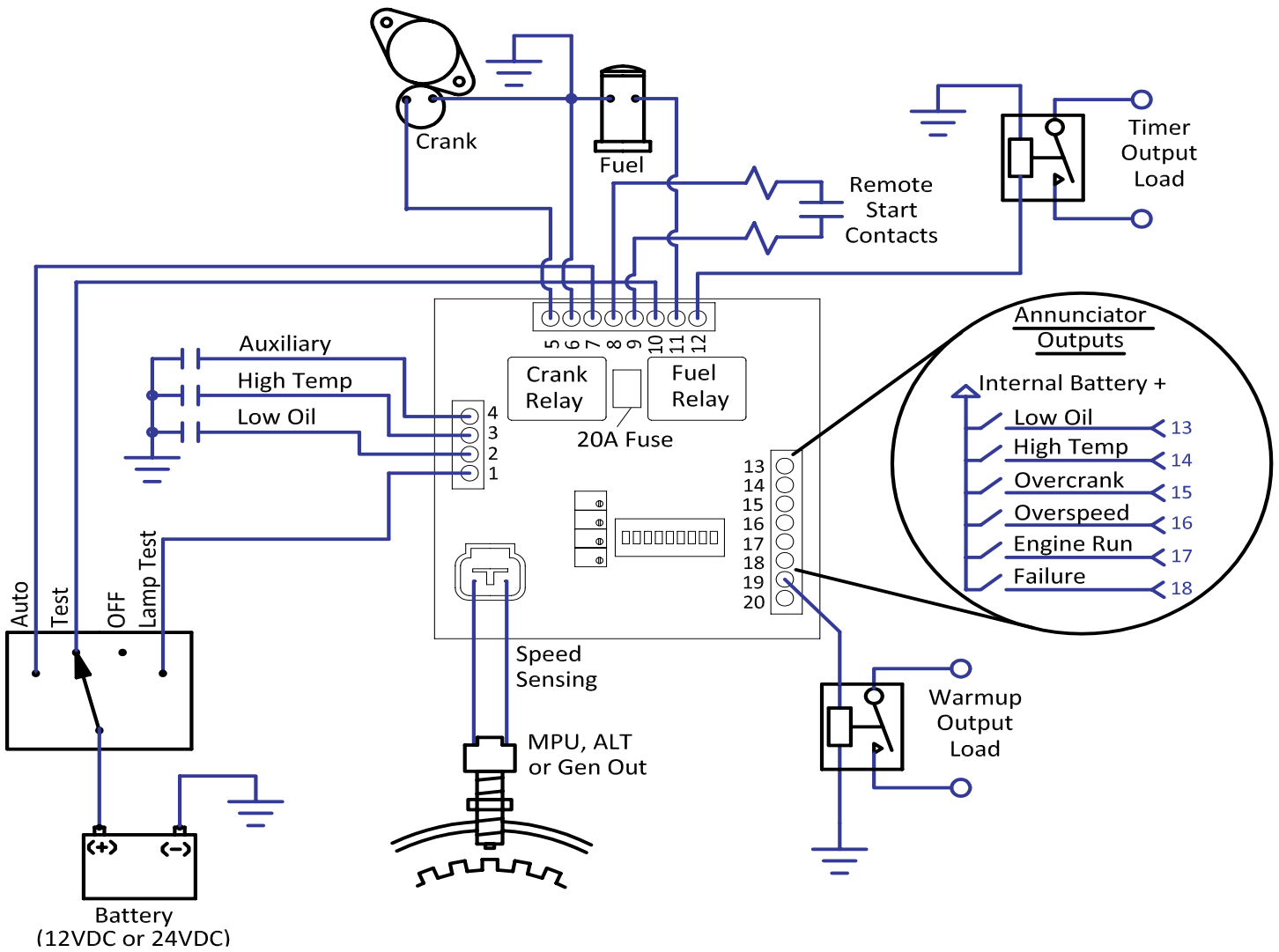

### SPECIFICATIONS

#### Operating Voltage

- 7 to 32 VDC continuous
- Standby Current Draw: 12mA
- Load Dump: J1113/11 Pulse 5a
- Reverse Polarity Protected

#### Operating Temperature

- -40 to +70C

#### Physical

- Dimensions: 3.3"H x 3.3"W x 1.8"D
- Weight: 0.67 lbs
- Industry standard mounting configuration
- Eurostyle removable connectors

#### Speed Sensing (user selectable sensing ranges)

- Magnetic pickup: 1V to 300V
- Generator Output: Up to 300VAC direct
- Accepts Tach signal from belt driven alternators

Loss of Speed signal protection during cranking and running (can be disabled while cranking)

#### Failure Inputs

- Low oil pressure failure\* (closed on failure)
- High engine temp failure\* (closed on failure)
- Auxiliary failure\* (closed on failure)

\*Failure inputs can close to either +battery or ground. All failure inputs are ignored for a period of 15 seconds at engine startup.

#### Outputs

- Fuel & Crank: high capacity replaceable automotive relays
- Rated 20A combined
- Switched to battery positive
- 12 or 24 VDC battery system (select appropriate relay for system voltage)
- Short circuit & overload protection on annunciation outputs (rated 300max)