

# GSC400Plus Digital Genset Controller

## Displays AC Volts/Amps Standard or Electronic Engines

The GSC400Plus is designed to provide complete control, protection, AC metering, and engine instrumentation for both standard and electronic engines and gensets. The module is easily configured using either the front panel buttons or our PC configurator software. The GSC400Plus provides direct mounting compatibility with other DynaGen controllers such as the GSC300 to allow for a full range of options to fit any application.



Compact 4.3" x 5.5" x 2.75" Footprint

### Displays:

- Oil Pressure • Engine Temperature
- Fuel Level • Oil Level
- Hour Meter • RPM
- 3-Phase AC Volts & Amps
- Frequency • Battery Voltage
- J1939 Diagnostic Codes
- Two customer-defined parameters (temperature, pressure, levels)

### Features and Functions:

- SAE J1939 Protocol.
- NFPA Level 1 Compliant.
- 3 On-Board 40A resistive Relays.
- Real-Time Clock.
- 100 Event Failure Log.
- Conformally coated for protection against moisture and contaminants.
- 8 Configurable Switched Inputs & 9 Configurable Switched Outputs.
- Autostart on Low Battery function.
- Built-in Engine Exerciser.
- Free PC Configurator Software.
- Front or Rear Mountable.
- Password protected.
- Modbus Port to connect remote annunciators and other devices.
- Options for remote monitoring over Internet and cellular.
- Accepts common senders (VDO, Datcon, Murphy, and more).
- Custom senders configurable with PC software.

- Dummy Load function to prevent wet stacking.
- Fan control function
- Options for Fuel OFF during Crank Rest, Restart on False Attempt and Locked Rotor.
- 5-Year Warranty.

## Easy-to-Use PC Configuration Software

Every setting of the feature-rich GSC400 is easily configured with its powerful, yet easy-to-use PC-based software interface.

Here are just some of the functions made available to you:



### 3 On-board Replaceable 40A Resistive Relays & Fuses

The GSC400 is socketed to accept three industry standard 40A resistive cube relays – each protected by a replaceable automotive fuse. The GSC400 eliminates the need to mount, wire, and fuse external slave relays for Fuel, Crank, and Preheat.

### Front Panel or PC Configurable

The GSC400 can be programmed manually via front panel buttons or with our easy-to-use PC software interface that provides customization of screen messages, sender selections, control settings, and much more.

### Ideal for Mobile Gensets

The GSC400 is a great fit for mobile and trailer genset applications:

- Ultra-Low Standby Draw prevents battery drain (50mA).
- Inputs to automatically re-configure for up to 4 different AC voltage topologies.
- Maintenance Timer.
- Inputs for fuel saving Idle Mode\*.

\* Compatible with Cummins Tier IV idle mode



## Typical Wiring Example

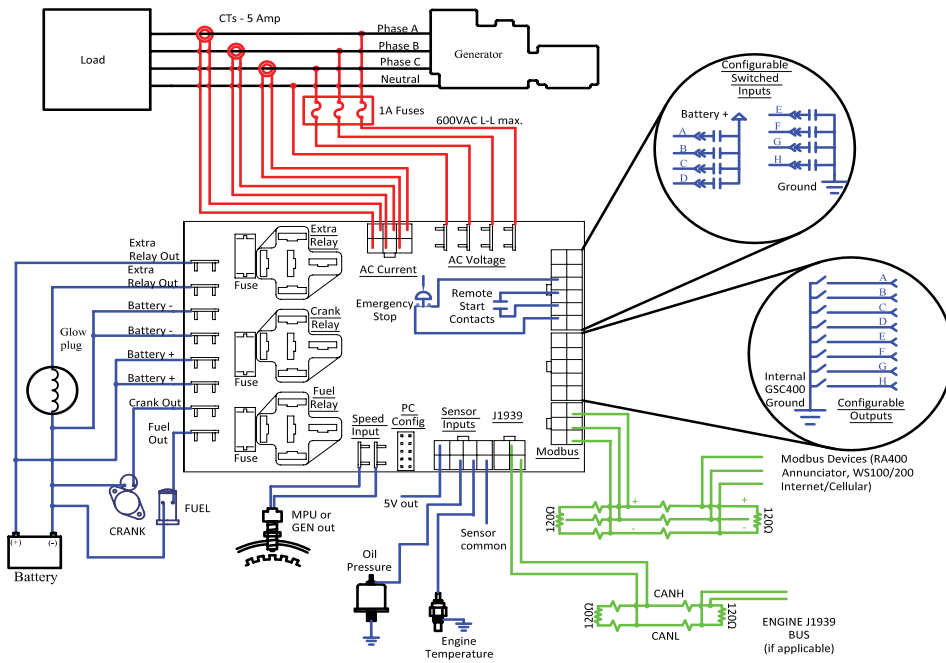

## Ordering Information

Part No. **GSC400-0-12-LSC\***

\*Comes with 12VDC relays installed.

### Available Accessories:

*RLY0054* - 24V relays; *RLY0054* - UL Listed 24V relays

*ACC0108* - S&W Oil Press Sender (279B-F) 100PSI, 240 Ohm, 1/8"-27 NPTF or 3/8" - 18 NPTF (c/w adaptor)

*ACC0122* + *ACC0125\** - Sensata Electronic Oil Press Sensor (Severe Duty) w/harness

*ACC0027* - DATCON Temp Sender 100-280C, 1/8"-27 NPTF

*GSC400-PGMRC* - USB/Serial Programming Kit with software

*ENCO057* - NEMA 1 Enclosure with vibration mounts

### Current Transformers:

*ACC0045* (100A), *ACC0046* (200A), *ACC0047* (300A), *ACC0048* (500A), *ACC0049* (600A), *ACC0050* (1000A), *ACC0057* (1500A), *ACC067* (2000A)

### Starter Harness Kits:

Harness kits are prewired in connector plugs and populated with common connection points for most applications. Extra crimp wires are available for further flexibility.

*ACC0086* - 5ft Starter Kit (AC Current Sensing, Switched Inputs, and Sensor Inputs)

*DWG1373* - 5ft J1939 Cable

*DWG1377* - 5ft Switched Outputs Cable

*DWG1410* - Pre-Crimped individual wires (pkg. of 5)

*DWG1454* - 5ft RS485/Modbus Cable



Also available with an optional control panel enclosure (**ENCO057**)

## SPECIFICATIONS

### Operating Voltage

- 7 to 32VDC with operation to 0VDC for 50mS

- Standby Current Draw: 50mA

- Reverse battery protected

- Surge withstand and Load Dump: SAE J1113/11

### Operating Temperature

- Controller Function: -40 to +70 °C

- Display Screen Viewing: -20 to +70 °C (consult factory for optional heater for -40 °C operation)

### Electromagnetic Compatibility

- Meets or exceeds MIL-STD-461E

### Physical

- Dimensions: 4.3"H x 5.5"W x 2.75"D

- Weight: 0.97 lb

### Speed Sensing

- Via J1939 bus, Magnetic pick-up, or Generator AC (up to 300VAC direct)

### Inputs

- Voltage Sensing:
  - Single-phase, 3-phase, Delta, Wye
  - Max 700vac
  - True RMS, +/- 1% of full scale

- Current Sensing:
  - Accepts 5A secondary CTs
  - +/- 2% of full scale

- Sensors:
  - Inputs 5, 6, 7: Sender (> 500Ω) or Switch\*
  - Inputs 2, 3, 4: Sender (0-500Ω) or Switch\*

\*Failure inputs must close to ground. All failure inputs are ignored for a adjustable bypass period.

- Configurable Switched Inputs:

- Inputs A,B,C,D (Close to Bat)

- Inputs E,F,G,H (Close to Gnd)

### Electronic Engine Support:

- Standard J1939 Engines (Tier II, II & IV)

- Customized display for Volvo, John Deere, Cummins, Yanmar, Detroit Diesel, Isuzu, GM PSI and more\*

\*Consult factory for updates

### Outputs

- Fuel, Crank & Extra Output - 40A resistive high capacity replaceable automotive relays:

- Switched to Battery Positive

- 12 or 24 VDC battery system (select appropriate relays for system voltage)

- Switched Outputs (A-H) - 200mA max:

- Switched to Ground

- Short circuit & overload protected

### Communications

- SAE J1939

- Tier II, III, & IV engines

- Address settings for both the GSC400 and the engine ECM

- Modbus:

- GSC400 operates in RTU Slave mode

- RS485 port (9600, 19200, 38400,

- 57600 baud)